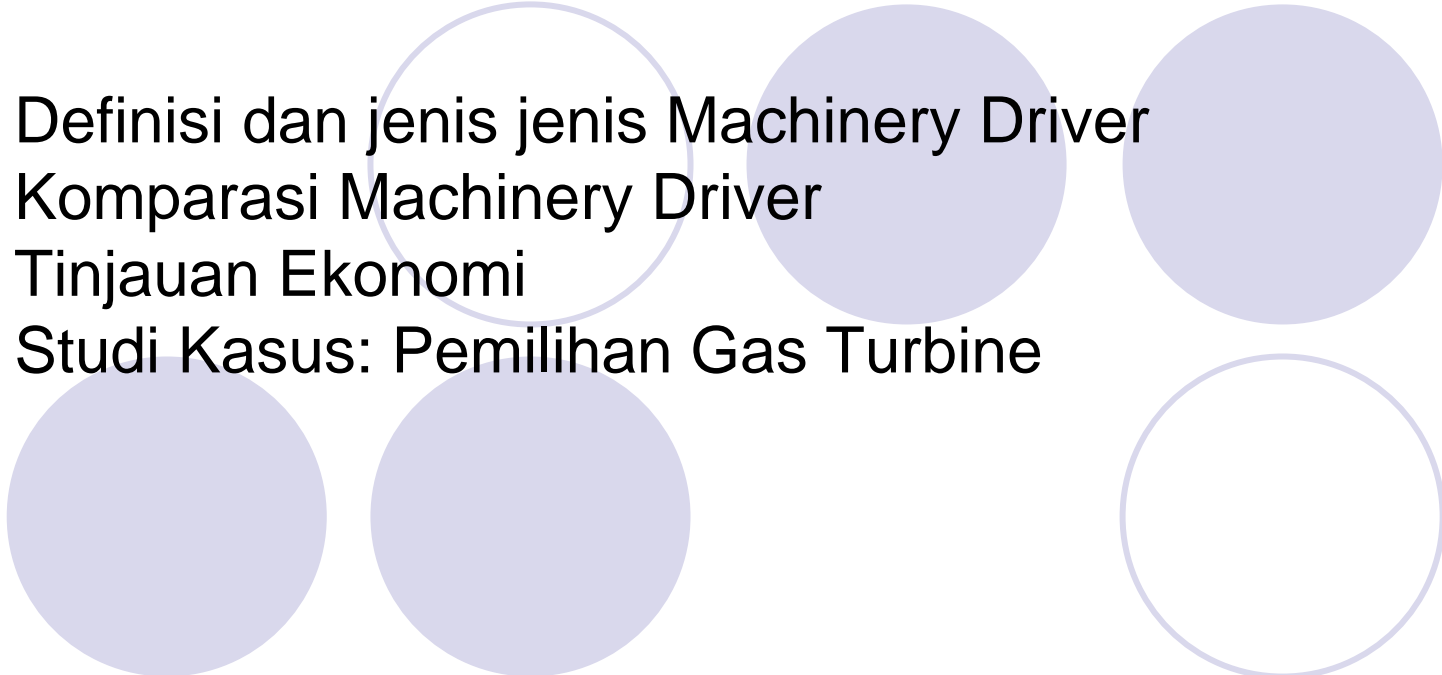

The slide features several decorative circles in a light purple color. One circle is positioned behind the letter 'i' in the title. Another circle is behind the letter 'e' in the subtitle. A third circle is behind the letter 'i' in the name. There are also two solid purple circles on the left side of the slide, one below the title and one below the subtitle.

# Machinery Driver Selection

Presented on PT Wijaya Karya Training, April 2005

Edi Hamdi

- 
- The slide features a decorative arrangement of six circles. One circle is white with a light blue outline and is positioned behind the first item of the list. The other five circles are solid light blue. They are arranged in two rows: the top row has three circles and the bottom row has three circles.
1. Definisi dan jenis jenis Machinery Driver
  2. Komparasi Machinery Driver
  3. Tinjauan Ekonomi
  4. Studi Kasus: Pemilihan Gas Turbine

***STRUKTUR PRESENTASI***

## ***DEFINISI***

Machinery Driver adalah peranti penggerak yang umumnya digunakan pada rotating equipment

## ***JENIS JENIS MACHINERY DRIVER***

- Electric Motor
- Internal Combustion Engine
- Steam Turbine
- Gas Turbine

## ***Electric Motor:***

- AC Motor with Constant Speed:
  - tipikal di industri, untuk pompa, kompressor, fan
  - most common: 3 phase squirrel-cage, 50 Hz
- AC Motor with Multispeed:
  - variable torque, constant torque, constant HP
- DC Motor:
  - speed bisa diadjust dalam range yang lebar

***ELECTRIC MOTOR***

## Gambar 29.1 Perry

Hal hal lain:

- Standard: NEMA or IEC
- Motor Starter
- Enclosure: TEFC, TEWAC, Explosion Hazard
- Motor Control
- Power Factor
- SF number

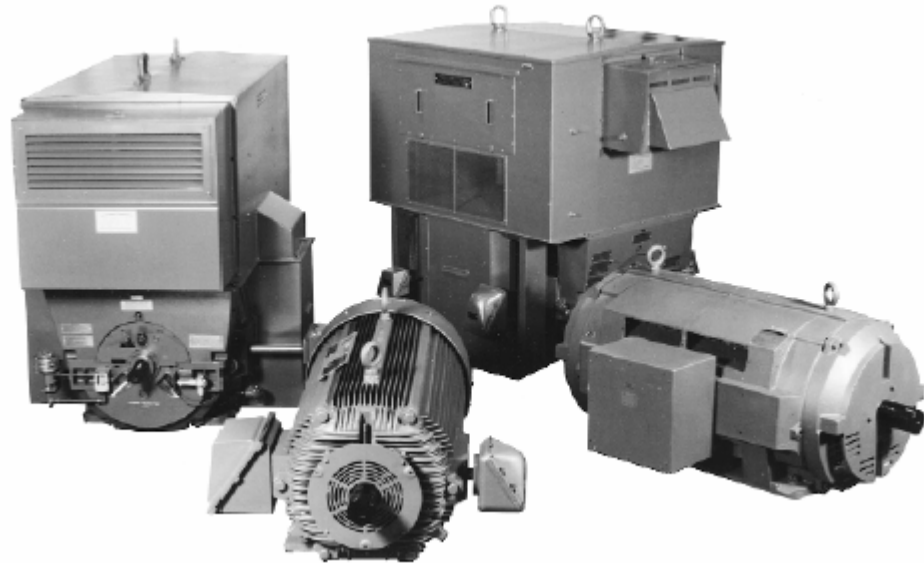

***ELECTRIC MOTOR***

## ***Internal Combustion Engine:***

- Gas Engine, Diesel Engine, Dual/Tri Fuel Engine
- Four / two cycle

Karakteristik Desain:

- Compression Ratio
- Piston speed
- BMEP
- Engine rating
- Turbocharging
- Fuel

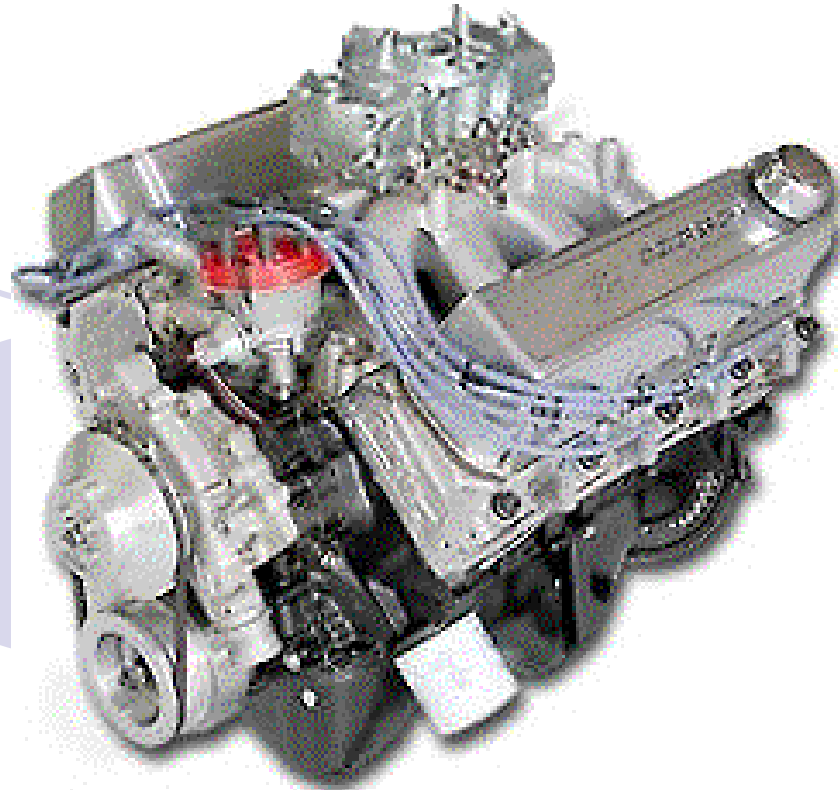

***INTERNAL COMBUSTION ENGINE***

# Gas Turbine :

- Industrial Heavy-Duty / Aeroderivative
- Electrical Power / Mechanical Drive

Compressor: Axial / Centrifugal

Combustor: Tubular, Can-annular, Annular

Turbine: Radial, Axial-Impulse, Axial-Reaction

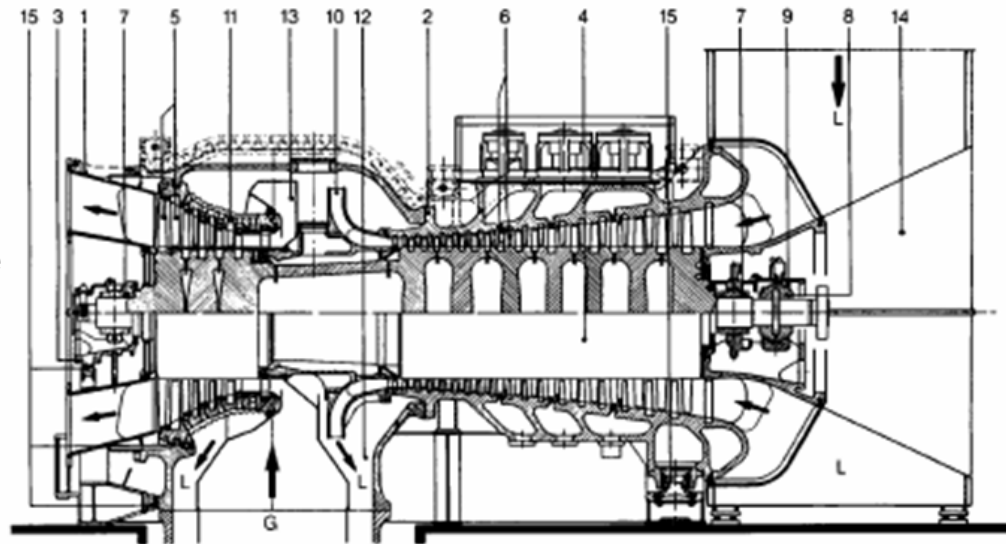
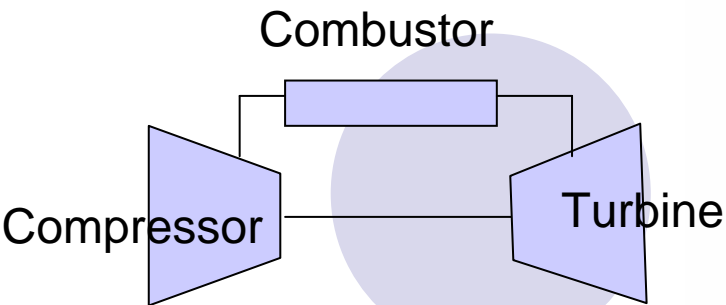

**GAS TURBINE**

- |  |                            |                      |
|--|----------------------------|----------------------|
| 1 - Turbine housing                    | 7 - Journal bearings       | 13 - Internal casing |
| 2 - Compressor housing                 | 8 - Thrust bearings        | 14 - Air intake      |
| 3 - Bearing body                       | 9 - Thrust bearing cover   | 15 - Position key    |
| 4 - Shaft                              | 10 - Diffuser              | L - Air              |
| 5 - Turbine rotor and stator blades    | 11 - Blade carrier         | G - Hot gas          |
| 6 - Compressor rotor and stator blades | 12 - Cooling-air admission |                      |

## ***Steam Turbine :***

- Condensing / Non Condensing
- Electrical Power / Mechanical Drive

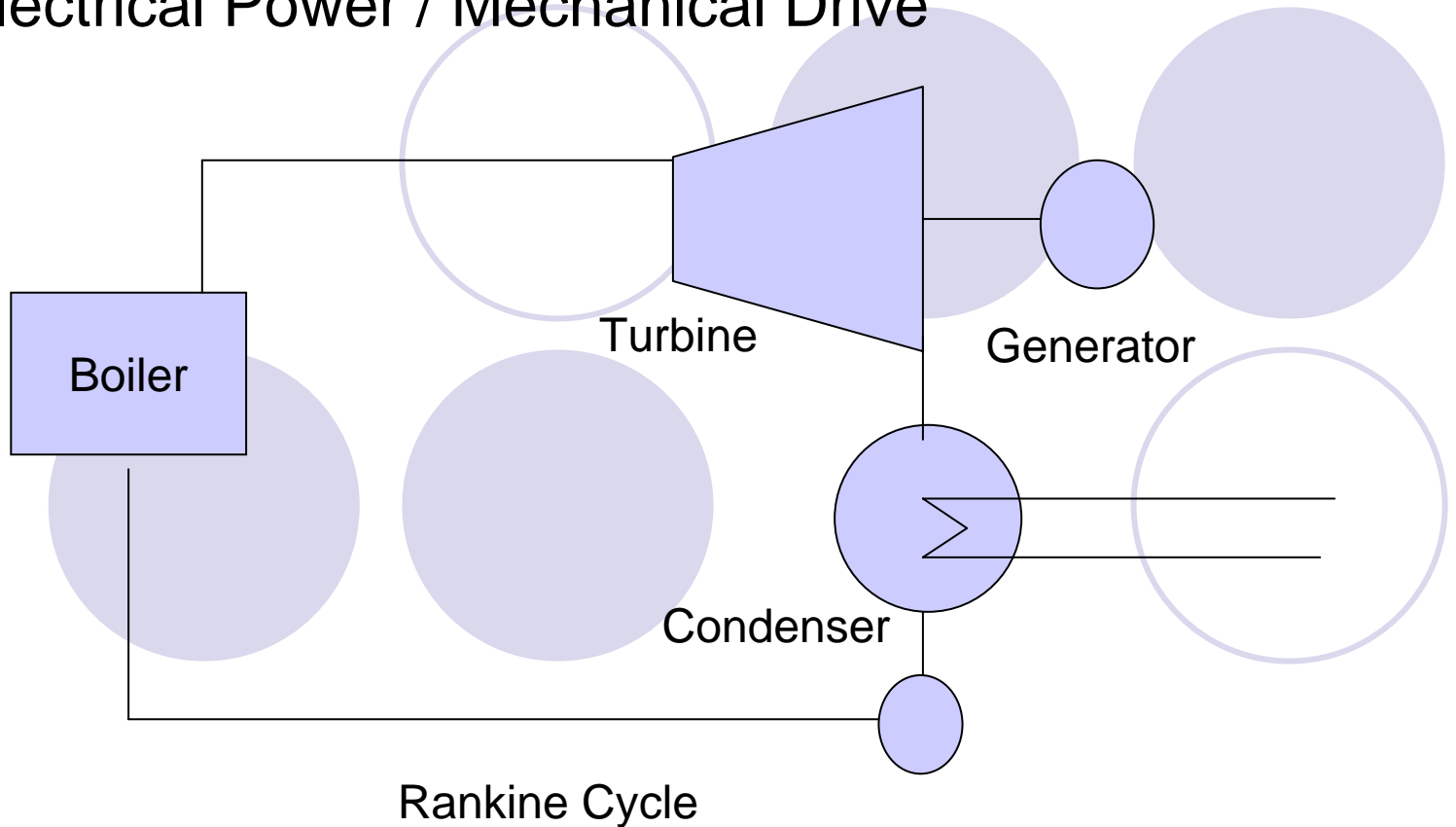

***STEAM TURBINE***

## Theoretical Steam Rates

Exhaust pressure	Inlet conditions							
	150 lb/in <sup>2</sup> gage, 366°F, saturated	200 lb/in <sup>2</sup> gage, 388°F, saturated	250 lb/in <sup>2</sup> gage, 500°F, 94°F superheat	400 lb/in <sup>2</sup> gage, 750°F, 302°F superheat	600 lb/in <sup>2</sup> gage, 750°F, 261°F superheat	600 lb/in <sup>2</sup> gage, 825°F, 336°F superheat	850 lb/in <sup>2</sup> gage, 825°F, 298°F superheat	850 lb/in <sup>2</sup> gage, 900°F, 373°F superheat
2 in. Hg.	10.52	10.01	9.07	7.37	7.09	6.77	6.58	6.28
4 in. Hg.	11.76	11.12	10.00	7.99	7.65	7.28	7.06	6.73
0 lb/sq. in. gage	19.37	17.51	15.16	11.20	10.40	9.82	9.31	8.81
10 lb/sq. in. gage	23.96	21.09	17.90	12.72	11.64	10.96	10.29	9.71
30 lb/sq. in. gage	33.6	28.05	22.94	15.23	13.62	12.75	11.80	11.07
50 lb/sq. in. gage	46.0	36.0	28.20	17.57	15.36	14.31	13.07	12.21
60 lb/sq. in. gage	53.9	40.4	31.10	18.75	16.19	15.05	13.66	12.74
70 lb/sq. in. gage	63.5	45.6	34.1	19.96	17.00	15.79	14.22	13.25
75 lb/sq. in. gage	69.3	48.5	35.8	20.59	17.40	16.17	14.50	13.51

## Typical Steam Turbine Selection Table

Wheel diameter, in	Base steam rate, lb/hp-hr	Power loss, hp	Total power, hp	Steam required, lb/hr	Steam rate, lb/hp-hr
14	44.5	3.0	303	13,500	44.6
18	37.0	8.5	308.5	11,400	38.1
22	33.0	26.0	326.0	10,750	36.9
28	29.5	64.0	364.0	10,750	36.9

**STEAM TURBINE**

## ***Tinjauan Ekonomi :***

- Efficiency
- Fuel Availability: Location, Reserves
- Utilities: Cooling System, Lubrication
- Space Available
- Site Rated Condition
- Price : vendors, published journal

Cost of driver A = Cost of driver B x

$$\left[ \frac{\text{Capacity Equipment A}}{\text{Capacity Equipment B}} \right]$$

0.6

***TINJAUAN EKONOMI***

## ***Gas Turbine :***

- Very Expensive: around USD 200 / HP
- Available in 'bad' increment size
- Compact size, short start-up
- Specified in Standard: ASME / ISO
- API margin requirement
- Site rated condition is a must

	ASME PTC-22	ISO
Temp.	80 F	59 F
Pressure	14.17 psia	14.7 psia
RH	50%	60%

***STUDI KASUS: GAS TURBINE SELECTION***

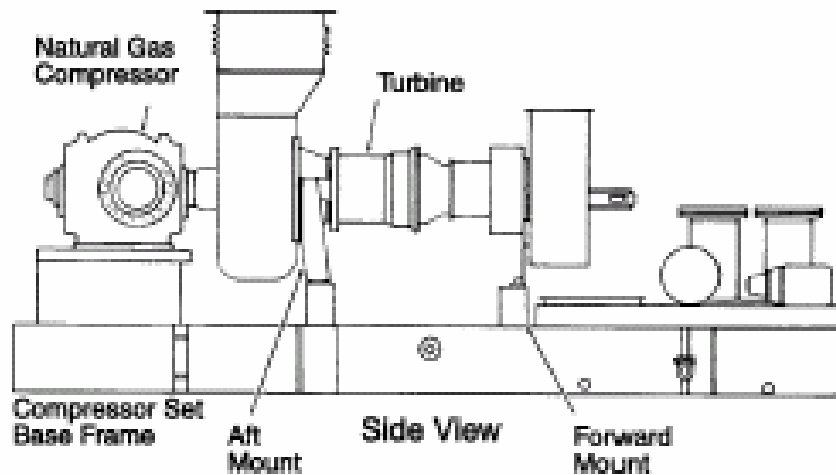
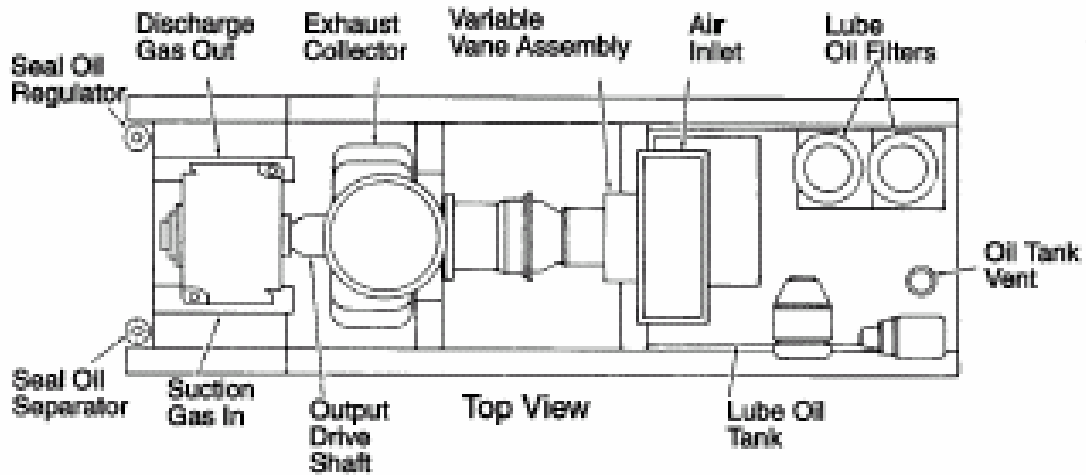

Courtesy of Solar Turbines Inc.

## ***STUDI KASUS: GAS TURBINE SELECTION***

## **Case:**

LNG Plant Data

Energy requirement: 12 kW/ton-day-LNG

LNG Production: 1 MTPA

Site condition:

Elevasi: 200m ASL

RH: 87%

Temperature maksimum: 37 deg C

***STUDI KASUS: GAS TURBINE SELECTION***

## Excerpt from Gas Turbine World Handbook:

Gas Turbine	ISO Rating Continuous	Efficiency	Package	Per Hp
M6581B	51340 HP	32.5%	\$10.300.000	\$200
LM6000	60000 HP	42.5%	\$12.100.000	\$202
Trent 50 DLE	70470 HP	42.9%	\$12.900.000	\$183
Trent 60 (water injection)	79050 HP	41.4%	\$14.000.000	\$180

***STUDI KASUS: GAS TURBINE SELECTION***

## Altitude Correction Factor

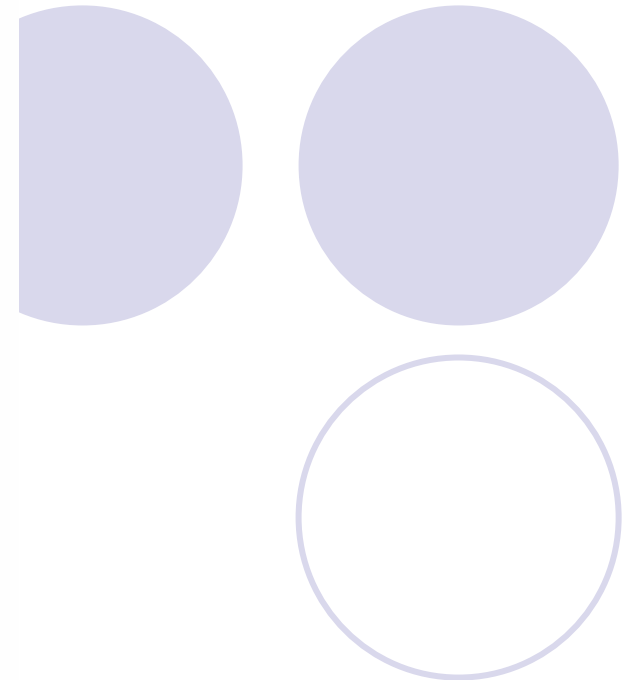
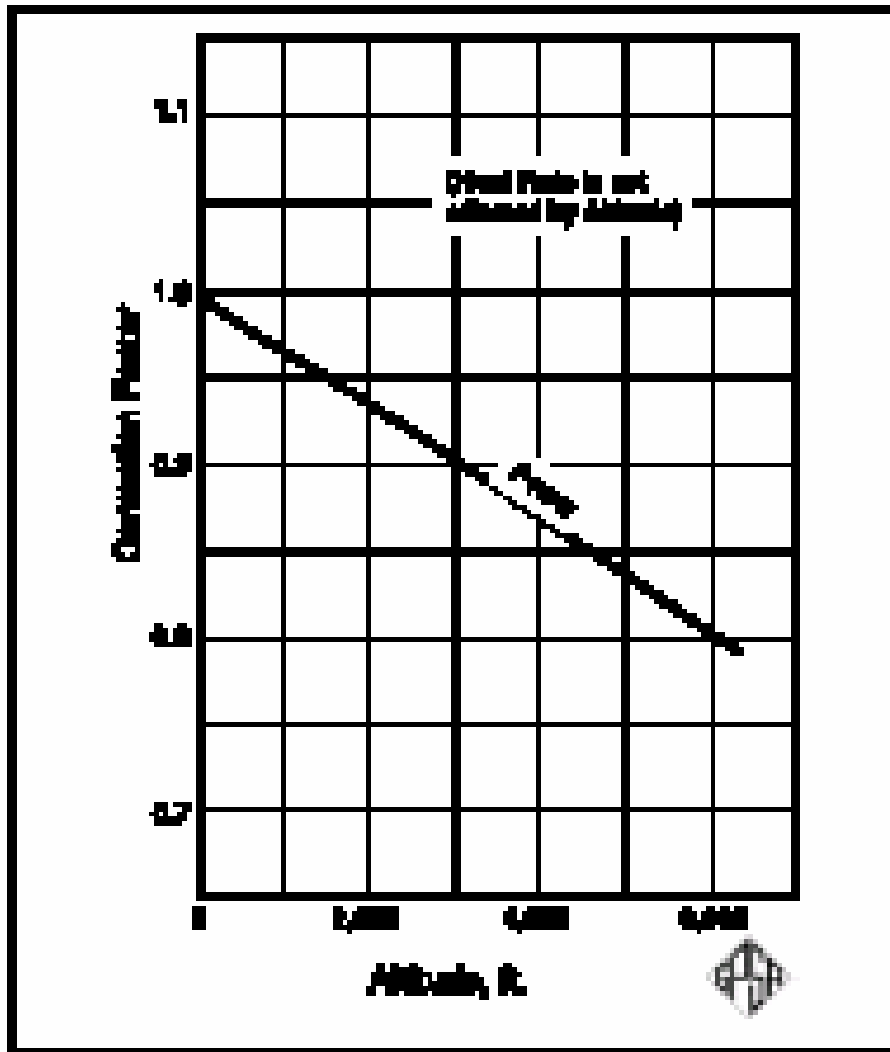

***STUDI KASUS: GAS TURBINE SELECTION***

Exhaust Loss Correction Factor

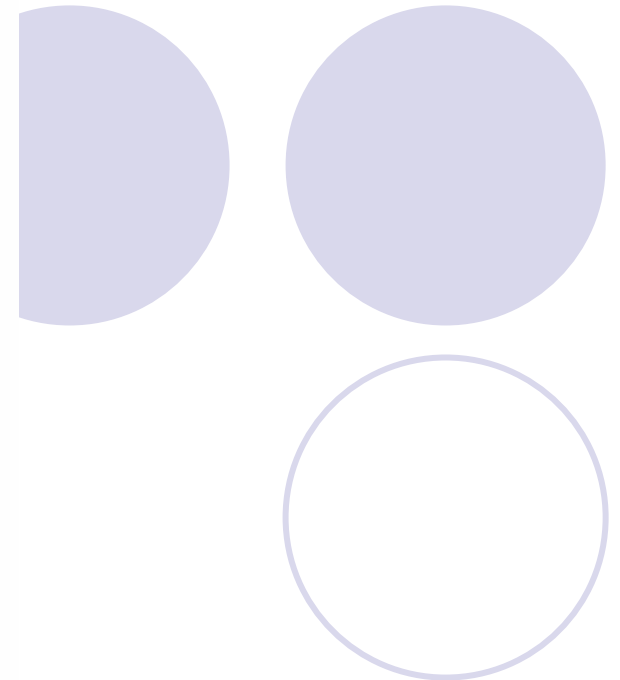
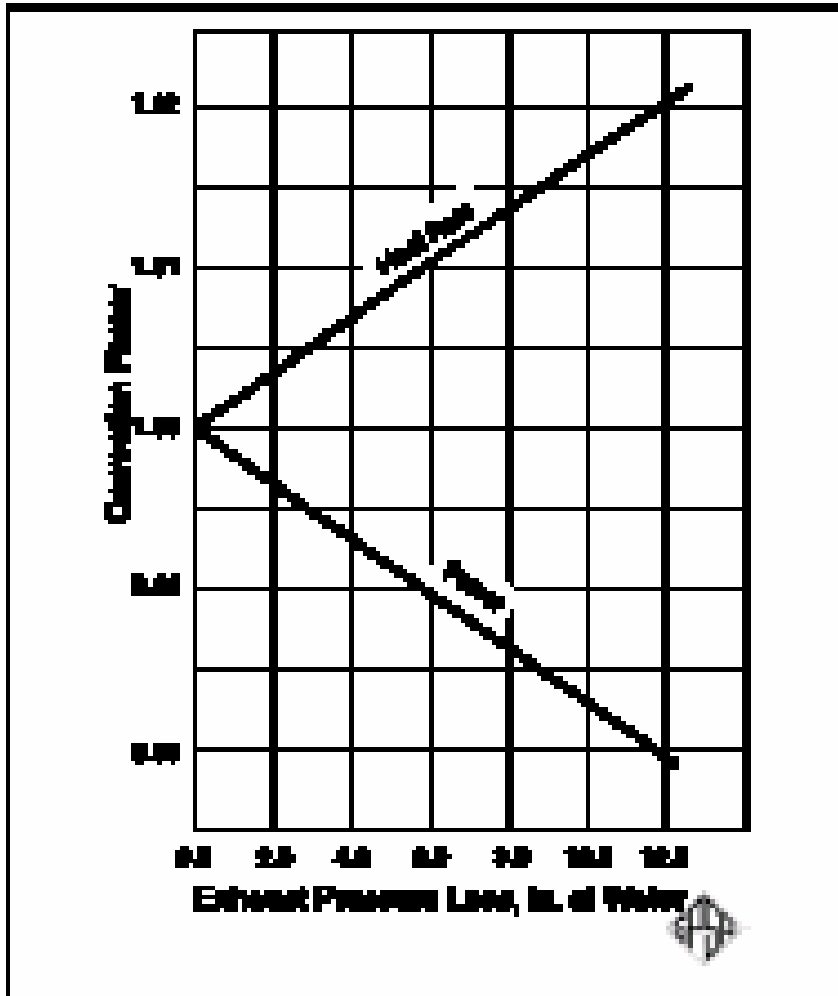

**STUDI KASUS: GAS TURBINE SELECTION**

## Correction Factor:

- Duct Loss: typically 4" drop across inlet and exhaust. Equivalent to 2% reduction in power available
- Gearbox Loss: typically 1.5% reduction in available power
- Auxiliary Loss: typically 0.6% reduction in available power
- Rule of Thumb:
  - GT power output drops by 0.3 to 0.5% for every 1 deg F increase in ambient temperature
  - GT power output drops by 3 to 4% for every 1000 ft change in altitude

***STUDI KASUS: GAS TURBINE SELECTION***