

Learning & Sharing

Computational Fluid Dynamics & Its Application in EPC Industry

Oleh: Edi Hamdi

Learning & Sharing

- **Background>**

- Knowledge gained from author's experience during his education in Denmark: 2001-2003

Oil & Gas Technology Program, Chemical Engineering & Flow Processes Research Group, Aalborg Universitet Esbjerg, Danmark

- Small discussion with CFD team ex-PTDI

- **Case Study>**

Computational Fluid Dynamics Application in Process and Oil & Gas Industries

Learning & Sharing

- **Definition**>

CFD> Computational Fluid Dynamics

Analysis of the systems involving **fluid flow**, **heat transfer** and associated phenomena such as **chemical reactions** by means of **computer-based simulation**

- **Applications**>

Process and Oil & Gas Industry>

System and Equipment Investigation

Design Improvement

Safety

Learning & Sharing

- **Advantages (over experiment based)**>

- Reduction of lead times and costs of new design
- Reverse engineering
- Study impossible experiment → very large system & hazardous
- Unlimited level of detail
- Steady/Unsteady; Compress/Incompress; 2D/3D system

- **Disadvantages**>

- Investment costs
- Simplification
- Finding the best or optimal setting
- Time consumption

Learning & Sharing

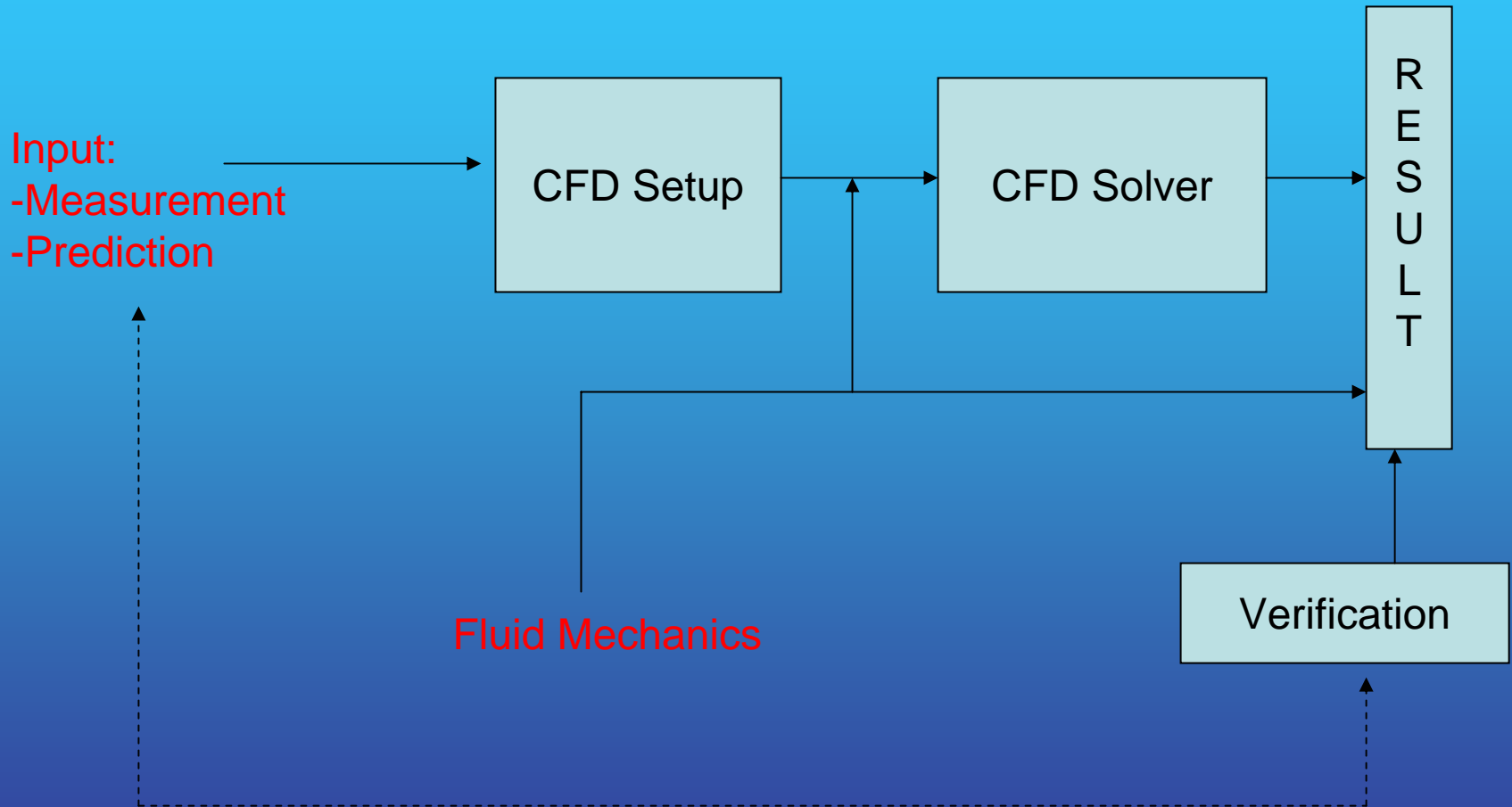

Learning & Sharing

CFD **Step-by-Step**

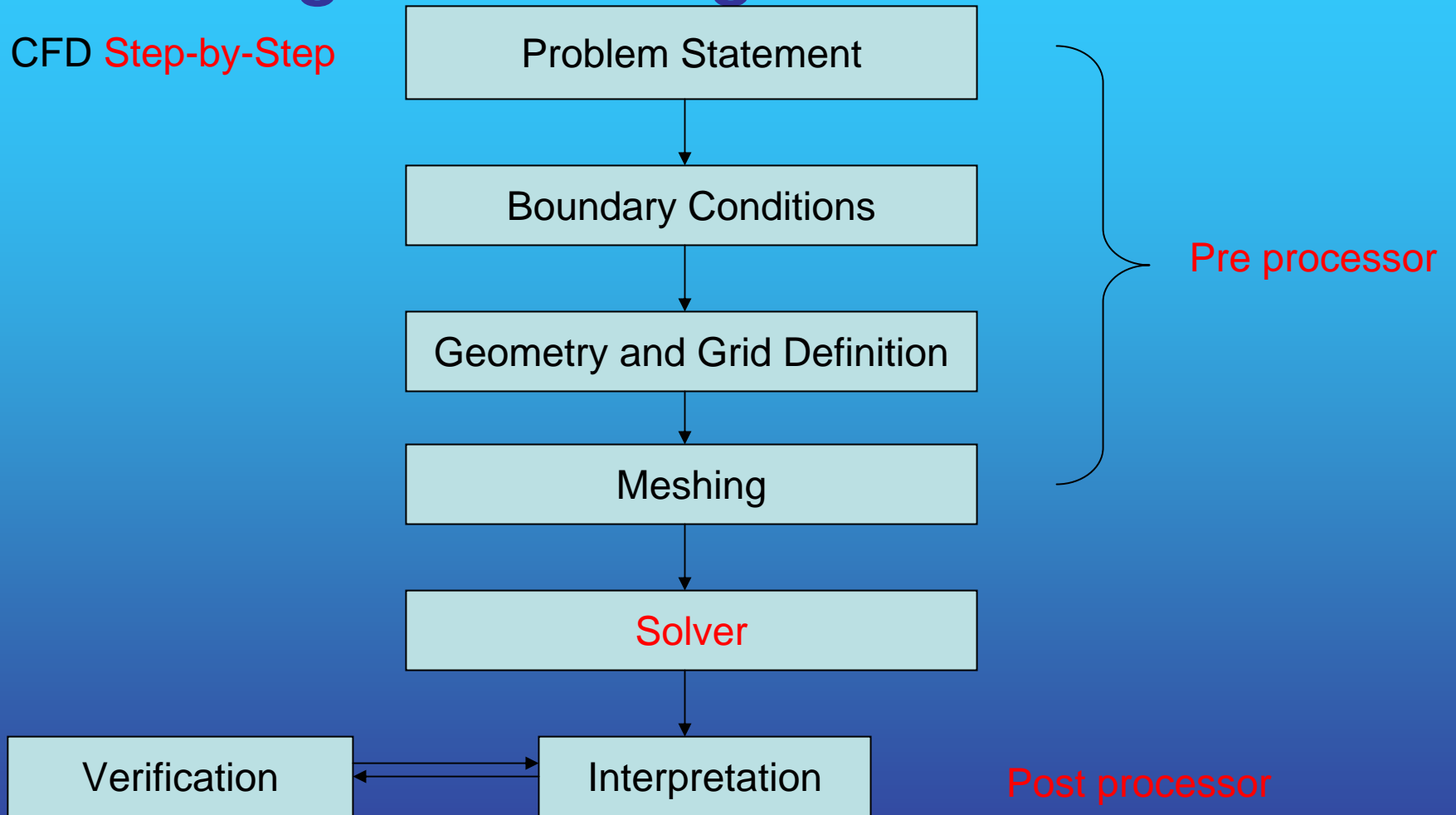

Learning & Sharing

Problem Statement

- Defining the problem:
 - steady or unsteady
 - 2D or 3D
 - compressible or incompressible
- Is there any verification sources?
- Accuracy level?
- What kind of results expected?
- Follow-up

Boundary Conditions

- Defining known boundary conditions
 - Temperature, Pressure, Velocity, etc.
- Defining fluid properties

Boundary Condition

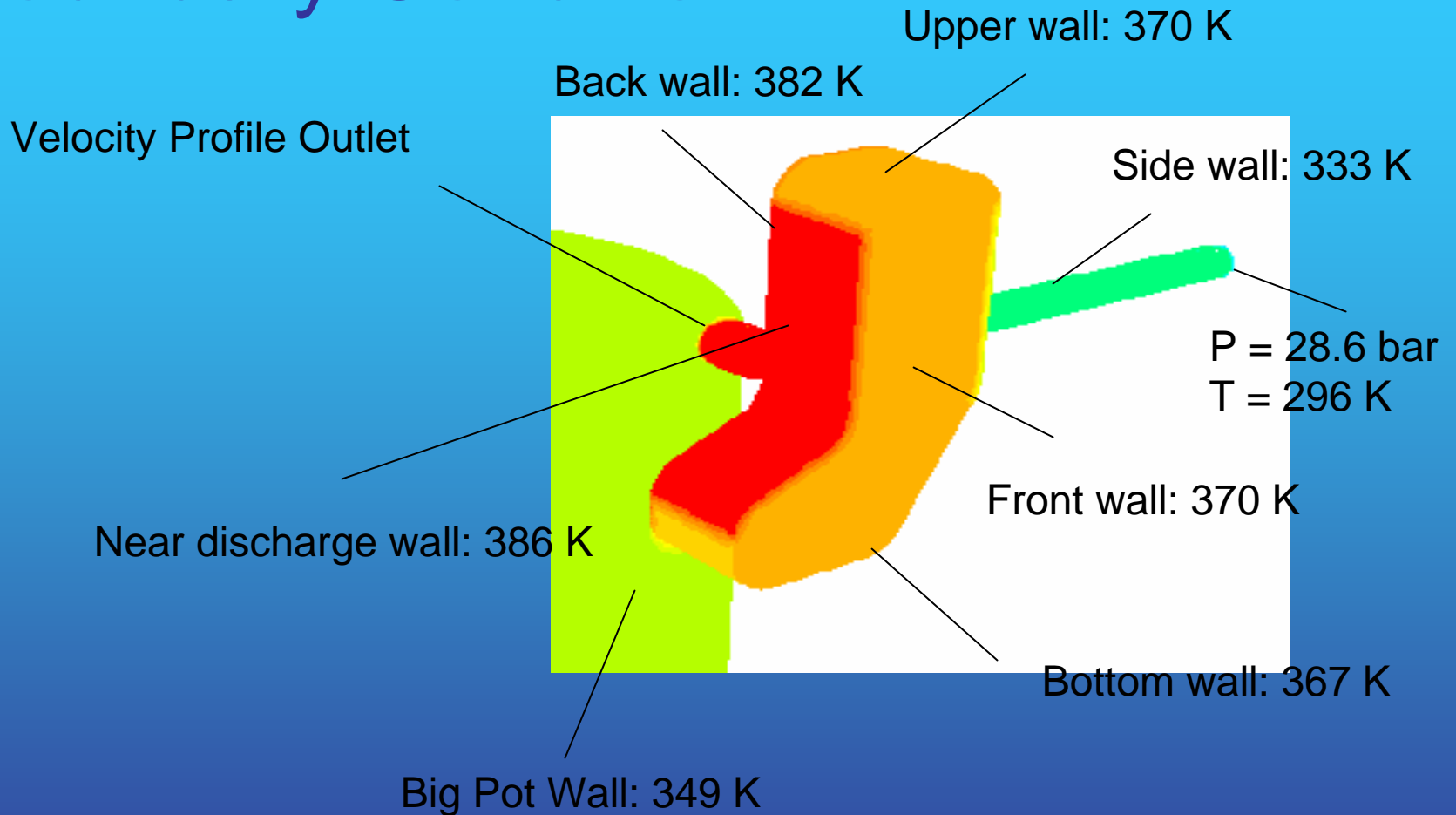

Learning & Sharing

Geometry and Grid Definition

- Defining **computational domain**
- **Grid**: sub division of the domain into a number of smaller sub domain

Meshing

- **Grid Generation**
- **Optimizing Grid Distribution**

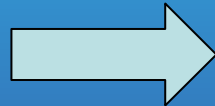

Over 50% of the time spent in CFD project

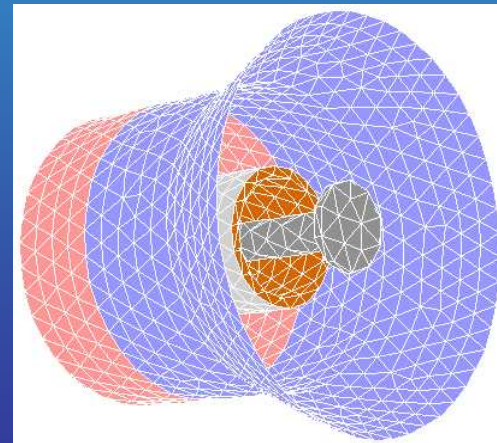
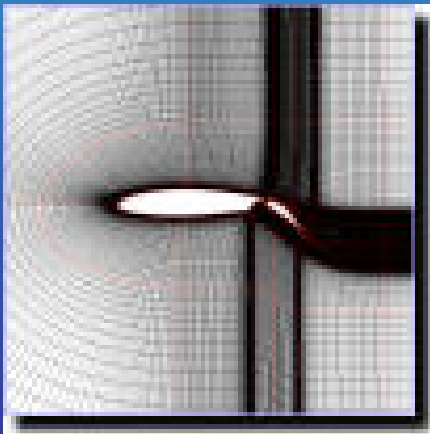

Learning & Sharing

Solver

Algebraic Equations:

- Mass Conservation
- Momentum Conservation
- Energy Conservation
- Equation of States
- Turbulence Model

➤ Numerical Solution Technique:

- Finite Difference
- Finite Element
- **Finite Volume Method**

- Fluid Mechanics **Interpretation**
- **Comparing** results
- **Optimization: Grid Adjustment, Discretisation Algorithm (under relax factor, etc)**

Verification

Interpretation



Learning & Sharing

- Application (based on author's experiences) >

Fire Investigation

Prediction of Temperature Distribution in Offshore Compartment

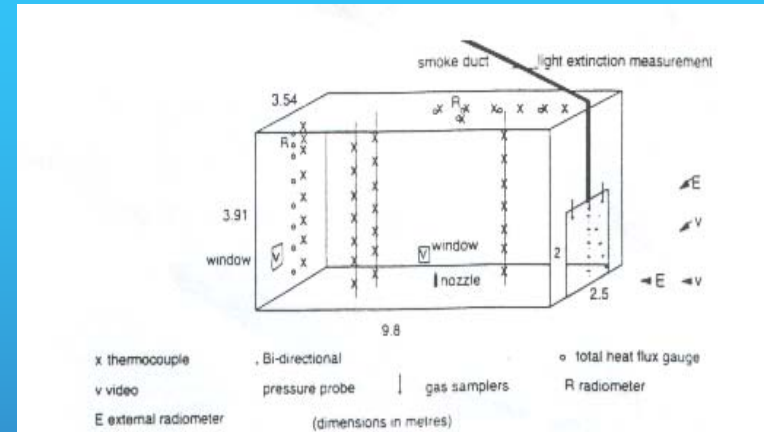

Heat Flux at Roof Test 1a, Emissivity : 1.0

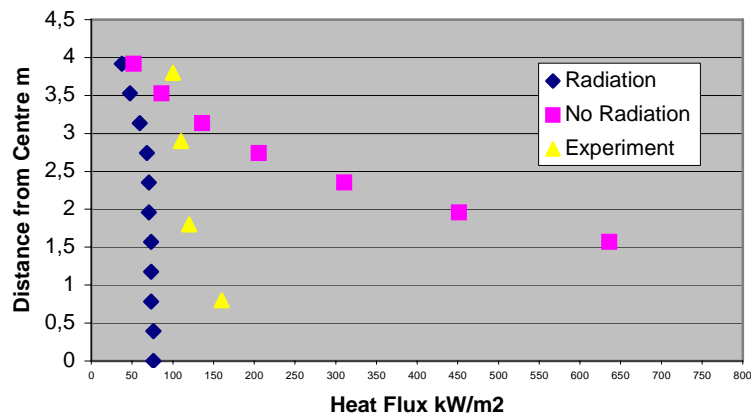

Temperature at Vent Test 1a

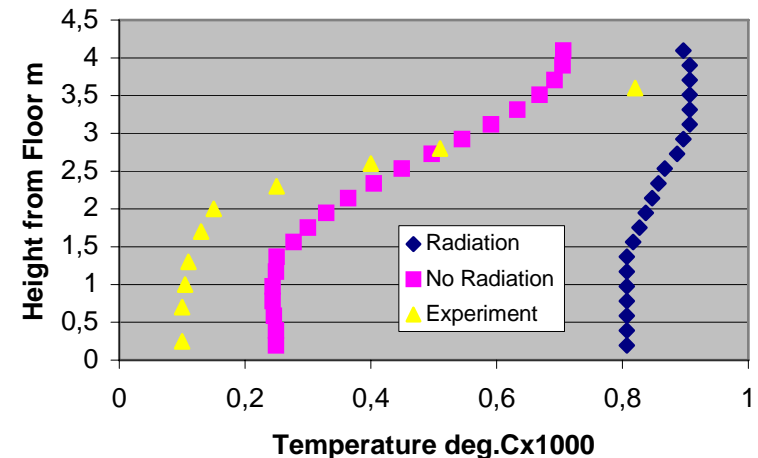

Learning & Sharing

- Application (based on author's experiences) >
 - Expansion Valve – Prediction of Cavitation Process in Expansion Valve during Throttling Processes

Vapour Phase Contour $dP=0.88$ bar

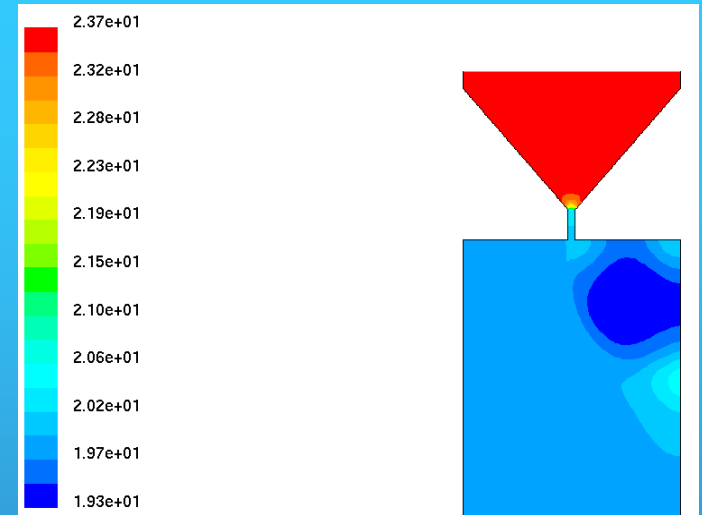

Pressure Drop against Mass Flow Rate

$$m = cA(2dpp)^{0.5}$$

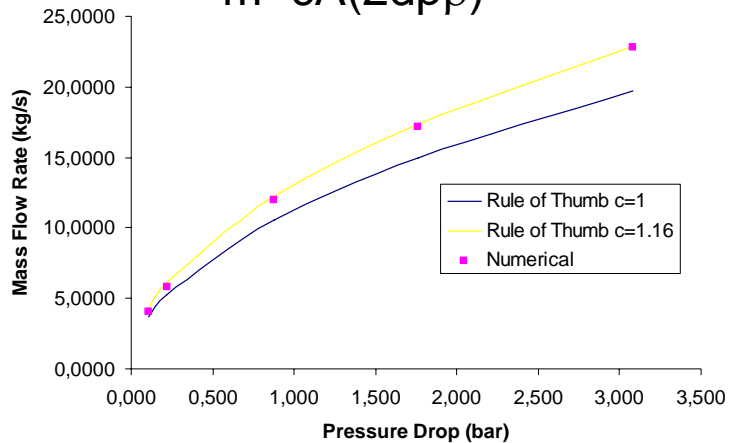

- $cl-dp=3.08$
- $cl-dp=1.76$
- $cl-dp=0.88$

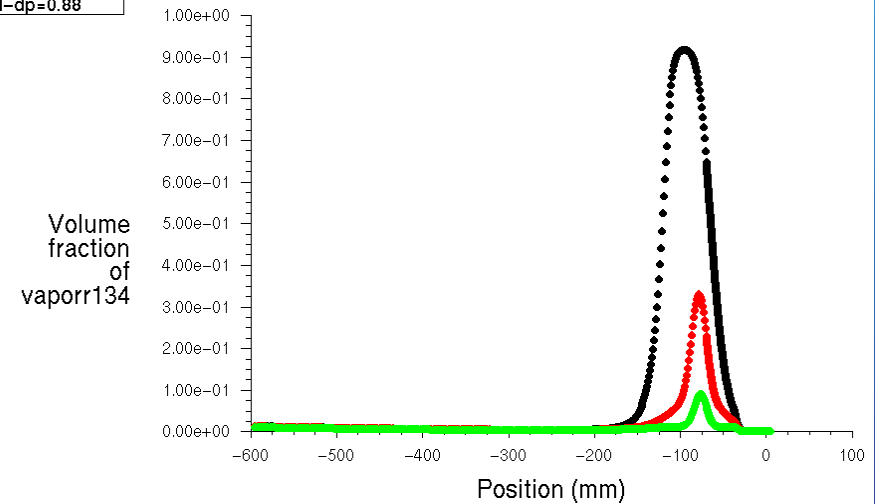

Vapour Fraction for Various Pres. Drop Evaluated along centre line

Learning & Sharing

- Application (based on author's experiences) >

Compressor's Suction
Gas Heating-

- Heat Transfer Evaluation
- Unsteady State
- 3D Model

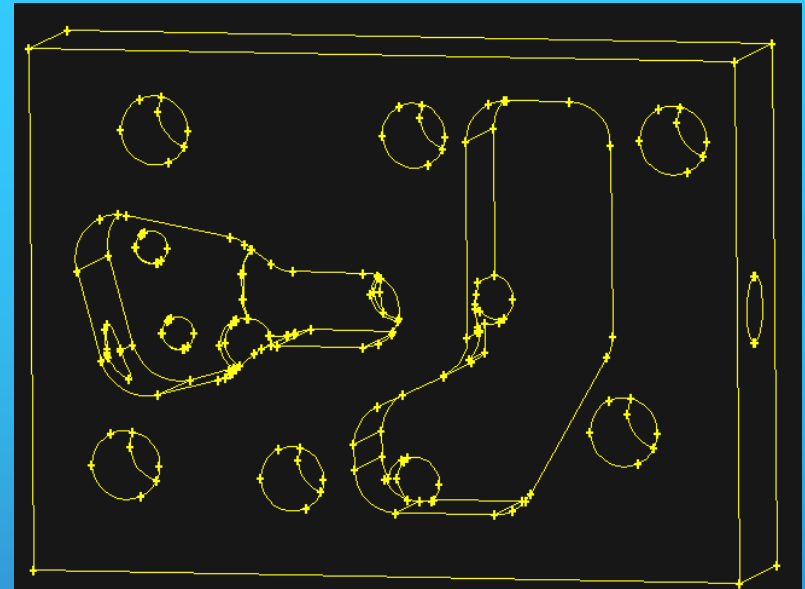

Temperature Gaining as Flow Time

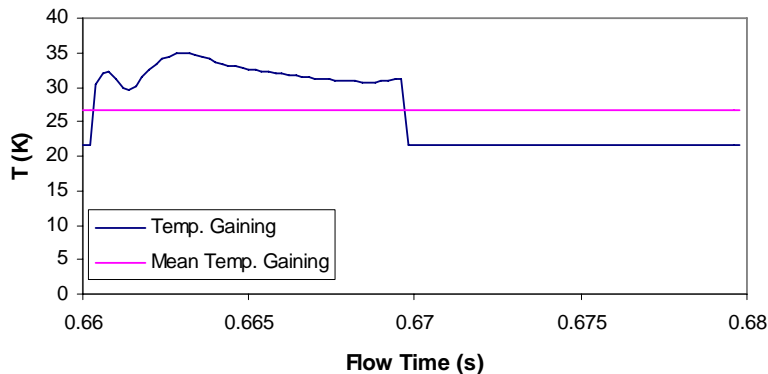

Density Losses as Flow Time

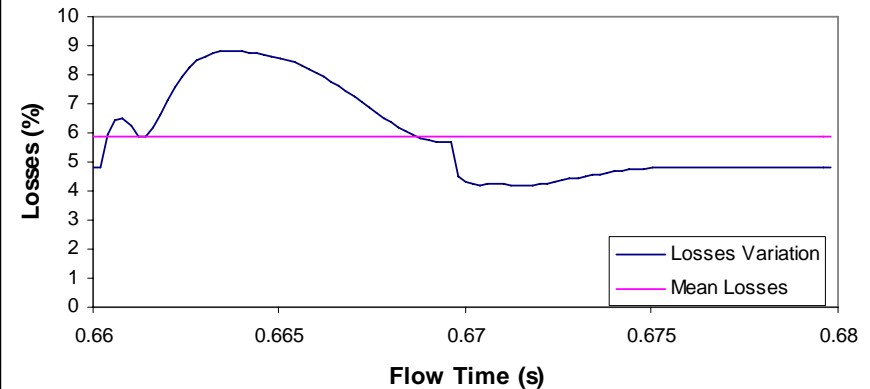

Learning & Sharing

(Compiled by ex PTDI)

- CFD used to troubleshoot centrifugal fan coal dust accumulation>



- CFD used to simulate methane leakage in gas turbin enclosure>

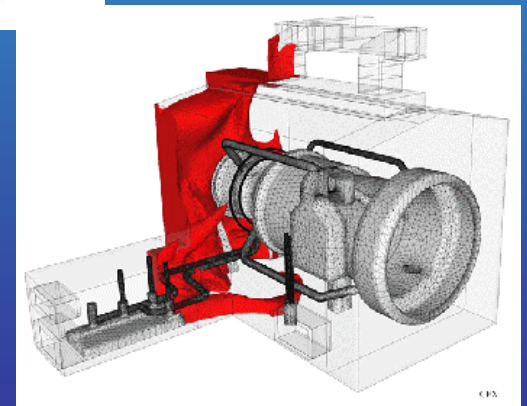

Learning & Sharing

- **Competitor's Stories**>

TEC- TEC CFD Analysis Services>

Heater Stack Height Optimization

Combustion Analysis: Furnace, Reformer

Optimization of Flow Distribution Devices

Optimization of Equipment Arrangement

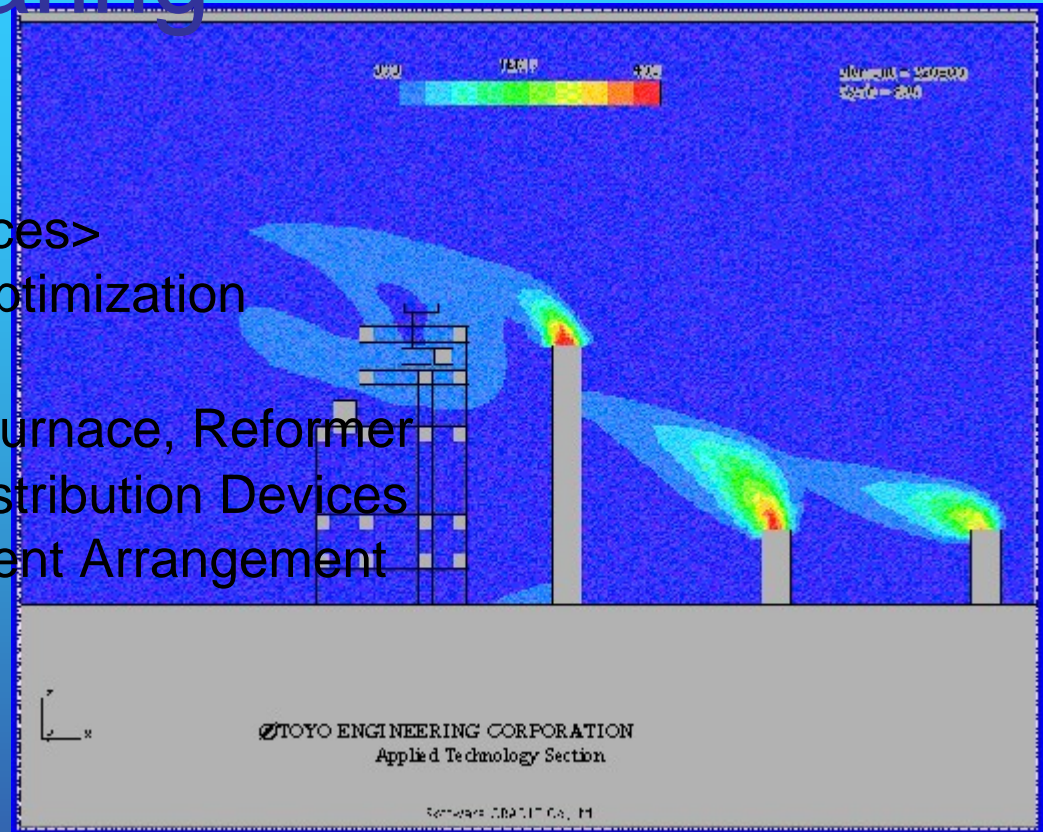

Bechtel & M.W. Kellogg>

Improve the energy of the recovery boiler by optimizing nozzle performance → Nozzle design

Learning & Sharing

- **Rekayasa's Review for using CFD**>

- **Expectations**>

Driving **Upstream** Engineering Capability especially in Fluid Dynamics and Process & Mechanical Design

- **Limitations**>

Software-Dependent

Simplification leads to inaccuracy

Time-consuming -> Meshing Independency

Verification -> Experiment test are not available

Error Analysis: **Modeling, Discretisation,**

Convergence

Learning & Sharing

- **Rekayasa's Review for using CFD**>

- **Strategies**>

- Corporation/outsourcing with academic institution

- Start try-out case

- > Eqp. design optimization/investigation:

- Separator, Heat Exchanger, Combustion

- > Arrangement optimization

- Critical system > Cost saving

- Interfacing with other CAE/CAD

- > HTRI: detail analysis of HE

- > PDS: hazardous area

- > others